



**Design No. U301
BXUV.U301
Fire Resistance Ratings - ANSI/UL 263**

Page Bottom

Design/System/Construction/Assembly Usage Disclaimer

- Authorities Having Jurisdiction should be consulted in all cases as to the particular requirements covering the installation and use of UL Certified products, equipment, system, devices, and materials.
- Authorities Having Jurisdiction should be consulted before construction.
- Fire resistance assemblies and products are developed by the design submitter and have been investigated by UL for compliance with applicable requirements. The published information cannot always address every construction nuance encountered in the field.
- When field issues arise, it is recommended the first contact for assistance be the technical service staff provided by the product manufacturer noted for the design. Users of fire resistance assemblies are advised to consult the general Guide Information for each product category and each group of assemblies. The Guide Information includes specifics concerning alternate materials and alternate methods of construction.
- Only products which bear UL's Mark are considered Certified.

BXUV - Fire Resistance Ratings - ANSI/UL 263

BXUV7 - Fire Resistance Ratings - CAN/ULC-S101 Certified for Canada

See General Information for Fire-resistance Ratings - ANSI/UL 263

See General Information for Fire Resistance Ratings - CAN/ULC-S101 Certified for Canada

Design No. U301

August 31, 2016

Bearing Wall Rating — 2 Hr.

Finish Rating — 66 Min.

This design was evaluated using a load design method other than the Limit States Design Method (e.g., Working Stress Design Method). For jurisdictions employing the Limit States Design Method, such as Canada, a load restriction factor shall be used — See Guide BXUV or BXUV7

*** Indicates such products shall bear the UL or cUL Certification Mark for jurisdictions employing the UL or cUL Certification (such as Canada), respectively.**

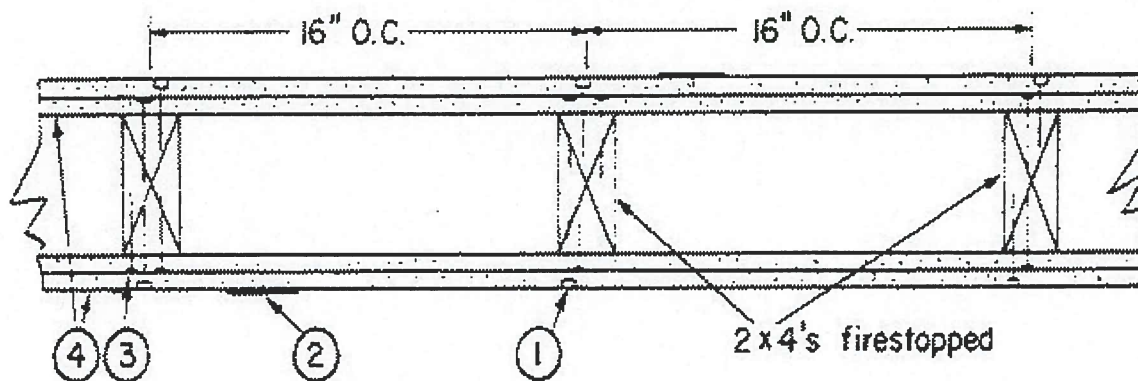

- 1. Nailheads** — Exposed or covered with joint compound.
- 2. Joints** — Exposed joints covered with joint compound and paper tape. Joint compound and paper tape may be omitted when square edge boards are used. As an alternate, nom 3/32 in. thick gypsum veneer plaster may be applied to the entire surface of Classified veneer baseboard with the joints reinforced with paper tape.
- 3. Nails** — 6d cement coated nails 1-7/8 in. long, 0.0915 in. shank diam, 1/4 in. diam heads, and 8d cement coated nails 2-3/8 in. long, 0.113 in. shank diam, 9/32 in. diam heads.
- 4. Gypsum Board*** — 5/8 in. thick, two layers applied either horizontally or vertically. Inner layer attached to studs with the 1-7/8 in. nails spaced 6 in. OC. Outer layer attached to studs over inner layer with the 2-3/8 in. long nails spaced 8 in. OC. Vertical joints located over studs. All joints in face layers staggered with joints in base layers. Joints of each base layer offset with joints of base layer on opposite side.

When used in widths other than 48 in., gypsum board to be installed horizontally.

When **Steel Framing Members*** (Items 6 or 6A) are used, base layer attached to furring channels with 1 in. long Type S bugle-head steel screws spaced max 24 in. OC; face layer attached with 1-5/8 in. long Type S bugle-head steel screws spaced max 12 in. OC.

ACADIA DRYWALL SUPPLIES LTD — Type X, 5/8 Type X, Moisture Resistant Type X, Gypsum Sheathing Type X, Mold & Mildew Resistant Type X and Mold & Mildew Resistant AR Type X, Type Blueglass Exterior Sheathing

AMERICAN GYPSUM CO — Types AGX-1, M-Glass, AG-C, AGX-11

BEIJING NEW BUILDING MATERIALS PUBLIC LTD CO — Type DBX-1

CERTAINTED GYPSUM INC — Types 1, FRPC, EGRG, GlasRoc, Type C, Type X, Type X-1

CGC INC — Types AR, C, IP-AR, IP-X1, IP-X2, IPC-AR, SCX, SHX, ULX, USGX, WRC, WRX

CONTINENTAL BUILDING PRODUCTS OPERATING CO, L L C — Types LGFC2A, LGFC6A, LGFC-C/A, LGFC-WD, LGLLX

GEORGIA-PACIFIC GYPSUM L L C — Types 5, 6, 9, C, DAP, DD, DA, DAPC, DGG, DS, GPFS6, LS, TG-C, Type X, Veneer Plaster Base-Type X, Water Rated-Type X, Sheathing Type-X, Soffit-Type X, GreenGlass Type X, Type LWX, Veneer Plaster Base-Type LWX, Water Rated-Type LWX, Sheathing Type-LWX, Soffit-Type LWX, Type DGLW, Water Rated-Type DGLW, Sheathing Type-DGLW, Soffit-Type DGLW, Type LW2X, Veneer Plaster Base - Type LW2X, Water Rated - Type LW2X, Sheathing - Type LW2X, Soffit - Type LW2X, Type DGL2W, Water Rated - Type DGL2W, Sheathing - Type DGL2W

NATIONAL GYPSUM CO — Types eXP-C, FSK, FSK-C, FSK-G, FSW, FSW-3, FSW-5, FSW-6, FSW-8, FSW-C, FSW-G, FSMR-C, FSL

PABCO BUILDING PRODUCTS L L C, DBA PABCO GYPSUM — Types C, PG-2, PG-3, PG-3W, PG-4, PG-5, PG-5W, PG-5WS, PG-9, PG-11, PG-C or PGS-WRS

PANEL REY S A — Types PRC, PRC2, PRX, RHX, MDX, ETX, GREX

SIAM GYPSUM INDUSTRY (SARABURI) CO LTD — Type EX-1

THAI GYPSUM PRODUCTS PCL — Type C or Type X

UNITED STATES GYPSUM CO — Types AR, C, FRX-G, IP-AR, IP-X1, IP-X2, IPC-AR, SCX, SHX, ULIX, ULX, USGX, WRC, WRX

USG BORAL ZAWAWI DRYWALL L L C SFZ — Types C, SCX

USG MEXICO S A DE C V — Types AR, C, IP-AR, IP-X1, IP-X2, IPC-AR, SCX, SHX, ULX, USGX, WRC, WRX

4A. **Gypsum Board*** — (As an alternate to Item 4) — Nom 3/4 in. thick, installed as described in Item 4.

CGC INC — Types AR, IP-AR

UNITED STATES GYPSUM CO — Types AR, IP-AR

USG MEXICO S A DE C V — Types AR, IP-AR

4B. **Gypsum Board*** — (As an alternate to Items 4 and 4A) — 5/8 in. thick, 2 ft wide, tongue and groove edge, applied horizontally as the outer layer to one side of the assembly. Secured as described in Item 4. Joint covering (Item 2) not required.

CGC INC — Type SHX

UNITED STATES GYPSUM CO — Type SHX

USG MEXICO S A DE C V — Type SHX

4C. **Gypsum Board*** — (As an alternate to Items 4, 4A or 4B — Not Shown) — For Direct Application to Studs Only- For use on one or both sides of the wall as the base layer or one or both sides of the wall as the face layer. Nom 5/8 in. thick lead backed gypsum panels with beveled, square or tapered edges, applied vertically. Vertical joints centered over studs and staggered min 1 stud cavity on opposite sides of studs. Wallboard secured to studs with 1-5/8 in. long Type W coarse thread gypsum panel steel screws spaced 8 in. OC at perimeter and in the field when applied as the base layer. When applied as the face layer screw length to be increased to 2-1/2 in. Lead batten strips required behind vertical joints of lead backed gypsum wallboard and optional at remaining stud locations. Lead batten strips, min 1-1/2 in. wide, max 10 ft long with a max thickness of 0.125 in. placed on the face of studs and attached to the stud with two 1 in. long Type S-12 pan head steel screws, F4j, one at the top of the strip and one at the bottom of the strip. Lead discs or tabs may be used in lieu of or in addition to the lead batten strips or optional at other locations. Max 3/4 in. diam by max 0.125 in. thick lead discs compression fitted or adhered over steel screw heads or max 1/2 in. by 1-1/4 in. by max 0.125 in. thick lead tabs placed on gypsum boards underneath screw locations prior to the installation of the screws. Lead batten strips to have a purity of 99.9% meeting the Federal specification QQ-L-201f, Grade "C". Fasteners for face layer gypsum panels (Items 4, 4A or 4B) when installed over lead backed board to be min 2-1/2 in. Type S-12 bugle head steel screws spaced as described in Item 4.

RAY-BAR ENGINEERING CORP — Type RB-LBG.

4D. **Gypsum Board*** — As an Alternate to Item 4 — 5/8 in. thick applied either horizontally or vertically. Inner layers fastened to framing with 1-1/4 in. long Type W coarse thread gypsum panel steel screws spaced a max 8 in. OC, with last screw 1 in. from edge of board. Outer layers fastened to framing with 1-7/8 in. long Type W coarse thread gypsum panel steel screws spaced a max 8 in. OC, with last screw 1 in. from edge of board. When used in widths other than 48 in., gypsum board to be installed horizontally. All joints in face layers staggered with joints in base layers. Joints of each base layer offset with joints of base layer on opposite side.

AMERICAN GYPSUM CO — Types AGX-1, M-Glass, AG-C

4E. **Gypsum Board*** — (As an alternate to Items 4 through 4D) — 5/8 in. thick, 4 ft. wide, paper surfaced applied vertically and secured as described in Item 4.

GEORGIA-PACIFIC GYPSUM L L C — Type X ComfortGuard Sound Deadening Gypsum Board

4F. **Gypsum Board*** — (As an alternate to Item 4) — Not to be used with item 6. 5/8 in. thick, 4 ft. wide, paper surfaced, applied vertically and secured as described in Item 4.

NATIONAL GYPSUM CO — SoundBreak XP Type X Gypsum Board

4G. **Gypsum Board *** — (As an alternate to Items 4 through 4F) — Nominal 5/8 in. thick, 4 ft wide panels, applied vertically and secured as described in Item 4.

PABCO BUILDING PRODUCTS L L C, DBA PABCO GYPSUM — Types QuietRock ES

4H. **Gypsum Board*** — (As an alternate to Item 4) — Not to be used with item 6. 5/8 in. thick, 4 ft. wide, paper surfaced, applied vertically and secured as described in Item 4.

CERTAINTED GYPSUM INC — Type SilentFX

4I. **Gypsum Board*** — (As an alternate to item 4) — 5/8 in. thick, two layers applied either horizontally or vertically. Inner layer attached to studs with 1-1/4 in. long Type W steel screws spaced 8 in. OC. Outer layer attached to studs over inner layer with 2 in. long Type W steel screws spaced 8 in. OC offset 6 in. from base layer. Vertical joints located over studs. Vertical and horizontal joints between inner and outer layers staggered. Outer layer joints covered with joint tape and compound, screwheads covered with joint compound. As an alternate to the joint compound nom 3/32 in. thick gypsum veneer plaster may be applied to the entire surface of Classified veneer baseboard. Joints reinforced. Wallboard other than 48 in. wide must be applied horizontally. The SoundBreak XP Type X Gypsum Board is not to be used with Item 6.

NATIONAL GYPSUM CO — Types eXP-C, FSK, FSK-C, FSK-G, FSW, FSW-3, FSW-5, FSW-6, FSW-C, FSW-G, FSMR-C, SoundBreak XP Type X Gypsum Board

4J. **Gypsum Board*** — (As an alternate to Items 4) — For Direct Application to Studs Only- For use as the base layer or as the face layer. Nom 5/8 in. thick lead backed gypsum panels with beveled, square or tapered edges, applied vertically. Vertical joints centered over studs and staggered min 1 stud cavity on opposite sides of studs. Wallboard secured to studs with 1-5/8 in. long Type W coarse thread gypsum panel steel screws spaced 8 in. OC at perimeter and in the field when applied as the base layer. When applied as the face layer screw length to be increased to 2-1/2 in. Lead batten strips required behind vertical joints of lead backed gypsum wallboard and optional at remaining stud locations. Lead batten strips, min 2 in. wide, max 10 ft long with a max thickness of 0.140 in. placed on the face of studs and attached to the stud with two 1 in. long Type S-8 pan head steel screws, one at the top of the strip and one at the bottom of the strip. Lead discs, max 5/16 in. diam by max 0.140 in. thick. compression fitted or adhered over the screw heads. Lead batten strips and discs to have a purity of 99.5% meeting the Federal specification QQ-L-201f, Grades "B, C or D". Fasteners for face layer gypsum panels (Items 4, 4A or 4B) when installed over lead backed board to be min 2-1/2 in. Type S-12 bugle head steel screws spaced as described in Item 4.

MAYCO INDUSTRIES INC — "X-Ray Shielded Gypsum"

4K. **Gypsum Board*** — For use with Item 7 — 5/8 in. thick, two layers applied vertically. Inner layer attached to resilient channels with 1 in. long steel screws spaced 8 in. OC. Outer layer attached to resilient channels over inner layer with 1-5/8 in. long steel screws spaced 8 in. OC. All joints in face layers staggered with joints in base layers. Joints of each base layer offset with joints of base layer on opposite side. Insulation, Items 8 or 9 is required.

AMERICAN GYPSUM CO — Types AGX-1, M-Glass, AG-C, AGX-11

4L. **Gypsum Board*** — (As an alternate to Items 4) — For Direct Application to Studs Only- For use as the base layer or as the face layer. Nom 5/8 in. thick lead backed gypsum panels with beveled, square or tapered edges, applied vertically. Vertical joints centered over studs and staggered min 1 stud cavity on opposite sides of studs. Wallboard secured to studs with 1-5/8 in. long Type W coarse thread gypsum panel steel screws spaced 8 in. OC at perimeter and in the field when applied as the base layer. When applied as the face layer screw length to be increased to 2-1/2 in. Lead batten strips required behind vertical joints of lead backed gypsum wallboard and optional at remaining stud locations. Lead batten strips, min 2 in. wide, max 8 ft long with a max thickness of 0.14 in. placed on the face of studs and attached to the stud with construction adhesive and two 1 in. long Type S-12 pan head steel screws, one at the top of the strip and one at the bottom of the strip. Lead discs, nominal 3/8 in. diam by max 0.085 in. thick. compression fitted or adhered over the screw heads. Lead batten strips and discs to have a purity of 99.9% meeting the Federal specification QQ-L-201f, Grade "C". Fasteners for face layer gypsum panels (Items 4, 4A or 4B) when installed over lead backed board to be min 2-1/2 in. Type S-12 bugle head steel screws spaced as described in Item 4.

RADIATION PROTECTION PRODUCTS INC — Type RPP - Lead Lined Drywall

4M. **Gypsum Board*** — (As an alternate to Item 4) — 5/8 in. thick, 4 ft. wide, two layers applied vertically with vertical joints centered over studs and staggered one stud cavity on opposite sides of studs. Secured as described in Item 4.

CERTAINTED GYPSUM INC — 5/8" Easi-Lite Type X

4N. **Gypsum Board*** — (As an alternate to 5/8 in. Type FSW in Items 4 or 4I) — Nom. 5/16 in. thick gypsum panels applied vertically or horizontally. Two layers of 5/16 in. for every single layer of 5/8 in. gypsum board described in Item 4 or 4I. Horizontal joints on the same side need not be staggered. Inner layer of each double 5/16 in. layer attached with fasteners, as described in item 4 or 4I, spaced 24 in. OC. Outer layer of each double 5/16 in. layer attached per Item 4 or 4I.

NATIONAL GYPSUM CO — Type FSW

4O. **Wall and Partition Facings and Accessories*** — (As an alternate to Items 4 through 4N) — Nominal 5/8 in. thick, 4 ft wide panels, applied vertically and secured as described in Item 4.

PABCO BUILDING PRODUCTS L L C, DBA PABCO GYPSUM — Type QuietRock 527

4P. **Gypsum Board*** — (As an alternate to Item 4) — 5/8 in. thick, two layers applied either horizontally or vertically. Inner layer attached to studs with 1-1/4 in. long Type W steel screws spaced 10 in. OC with the last two screws 4 and 1 in. from the edges of the board. Outer layer attached to studs over inner layer with 1-7/8 in. long Type W steel screws spaced 10 in. OC offset 5 in. from base layer with the last two screws 4 and 1 in. from the edges of the board. Vertical joints located over studs. Vertical and horizontal joints between inner and outer layers staggered. Outer layer joints covered with joint tape and compound, screwheads covered with joint compound. When used in widths other than 48 in., gypsum panels are to be installed horizontally.

CONTINENTAL BUILDING PRODUCTS OPERATING CO, L L C — Type LGFC6A, Type LGFC2A, Type LGFC-C/A, Type LGFC-WD, Type LGLLX

5. **Molded Plastic*** — Not Shown, Optional — Solid vinyl siding mechanically secured over the outer layer to framing members in accordance with manufacturer's recommended installation details.

ALSIDE, DIV OF ASSOCIATED MATERIALS INC

GENTEK BUILDING PRODUCTS LTD

VYTEC CORP

6. Steel Framing Members* — (Optional, Not Shown) — Furring channels and Steel Framing Members as described below:

A. Furring Channels — Formed of No. 25 MSG galv steel. 2-9/16 in. or 2-23/32 in. wide by 7/8 in. deep, spaced 24 in. OC perpendicular to studs. Channels secured to studs as described in Item b. Ends of adjoining channels are overlapped 6 in. and tied together with double strand of No. 18 SWG galv steel wire near each end of overlap. As an alternate, ends of adjoining channels may be overlapped 6 in. and secured together with two self-tapping #6 framing screws, min. 7/16 in. long at the midpoint of the overlap, with one screw on each flange of the channel. Wallboard attached to furring channels as described in Item 4.

B. Steel Framing Members* — Used to attach furring channels (Item 6a) to studs. Clips spaced 48 in. OC., and secured to studs with No. 8 x 2-1/2 in. coarse drywall screw through the center grommet. Furring channels are friction fitted into clips. RSIC-1 clip for use with 2-9/16 in. wide furring channels. RSIC-1 (2.75) clip for use with 2-23/32 in. wide furring channels.

PAC INTERNATIONAL L L C — Types RSIC-1, RSIC-1 (2.75)

6A. Steel Framing Members* — (Optional, Not Shown) — Furring channels and Steel Framing Members as described below:

A. Furring Channels — Formed of No. 25 MSG galv steel. Spaced 24 in. OC perpendicular to studs. Channels secured to studs as described in Item b. Ends of adjoining channels overlapped 6 in. and secured together with four self-tapping No. 8x1/2 Self Drilling screws (2 per side 1 in. and 4 in. from overlap edge). Gypsum board attached to furring channels as described in Item 4. Side joint furring channels shall be attached to studs with RESILMOUNT Sound Isolation Clips - Type A237R located approximately 2 in. from each end of length of channel. Both Gypsum Boards at side joints fastened into channel with screws spaced 8 in. OC, approximately 1/2 in. from joint edge.

B. Steel Framing Members* — Used to attach furring channels (Item 6Aa) to studs. Clips spaced 16 in. OC., and secured to studs with No. 10 x 2-1/2 in. coarse drywall screw through the center hole. Furring channels are friction fitted into clips.

STUDCO BUILDING SYSTEMS — RESILMOUNT Sound Isolation Clips - Type A237R

7. Furring Channel — Optional — Not Shown — For use on one side of the wall with Item 4K — Resilient channels, 25 MSG galv steel, spaced vertically 24 in. OC, flange portion screw attached to one side of studs with 1-1/4 in. long diamond shaped point, double lead Phillips head steel screws. When resilient channels are used, insulation, Item 8 or 9 is required.

8. Batts and Blankets* — Required for use with resilient channels, Item 7, min. 3 in. thick mineral wool batts, placed to fill interior of wall, attached to the nom 4 in. face of the studs with staples placed 24 in. OC.

ROXUL INC — Type SAFEnSOUND

THERMAFIBER INC — Type SAFB

9. Batts and Blankets* — (As an alternate to Item 8) — Min. 3 in. thick glass fiber batts bearing the UL Classification Marking as to Surface Burning and/or Fire Resistance, friction-fitted to fill the stud cavities. See Batts and Blankets (BKNV or BZJZ) Categories for names of Classified companies.

9A. Fiber, Sprayed* — (Optional) — As an alternate to Batts and Blankets (Item 8), Required for use with resilient channels, Item 7, Not for use with Item 6, or 6A. — Spray applied mineral wool insulation. The fiber is applied with water to completely fill the enclosed cavity in accordance with the application instructions supplied with the product. See Fiber, Sprayed (CCAZ).

AMERICAN ROCKWOOL MANUFACTURING, LLC — Type Rockwool

10. Wall and Partition Facings and Accessories* — (Optional, Not Shown) — Nominal 1/2 in. thick, 4 ft wide panels, for optional use as an additional layer on one or both sides of the assembly. Panels attached in accordance with manufacturer's recommendations. When the QR-500 or QR-510 panel is installed between the wood framing and the UL Classified gypsum board, the required UL Classified gypsum board layer(s) is/are to be installed as indicated as to fastener type and spacing, except that the required fastener length shall be increased by a minimum of 1/2 in. Not evaluated or intended as a substitute for the required layer(s) of UL Classified Gypsum Board.

PABCO BUILDING PRODUCTS L L C, DBA PABCO GYPSUM — Type QuietRock QR-500 or QR-510

11. Cementitious Backer Units* — (Optional Item Not Shown — For Use On Face Of 2 Hr Systems With All Standard Items Required) — 7/16 in., 1/2 in., 5/8 in., 3/4 in. or 1 in. thick, min. 32 in. wide. Applied vertically with vertical joints centered over studs. Face layer fastened over gypsum board to studs and runners with cement board screws of adequate length to penetrate stud by a minimum of 3/8 in. for steel framing members, and a minimum of 3/4 in. for wood framing members spaced a max of 8 in. OC.

NATIONAL GYPSUM CO — Type DuraBacker, PermaBase, DuraBacker Plus, or PermaBase Plus

12. Wall and Partition Facings and Accessories* — (Optional, Not Shown) - When the Wall Assembly is used as an External Wall, on the External side of the wall one of the following Wall and Partition and Facing Accessories may be used, refer to items (A) to (C) below.

A. Non Insulated system with metal channels — Install moisture barrier over the Gypsum Board Item 4 and Install Acry Metal Channels vertically at a horizontal spacing not greater than 24 inches OC., over the moisture barrier. Acry Metal Channels attached through the moisture barrier and the Gypsum Board to the Wood Studs using fasteners specified by the manufacturer and fasteners spaced max., 24 in. OC. Install Acrytec Panels on Acry Metal Channels using 1-1/4" long corrosion coated stainless steel screws spaced at a max spacing of 24 inches OC, along with manufacturer's approved adhesive (3M 540 or Tremco Vulcum 116). Adhesive to be applied in a zigzag pattern along every channel. Joint treatment in between panels shall be Tremco illmod 600 pre compressed polyurethane foam sealant.

B. Insulated system with metal channels — Install moisture barrier over the Gypsum Board Item 4. Install galvanized Z girt channels specified by the manufacturer over the moisture barrier and the Gypsum Board Item 4. Z girt channels to be installed horizontally at a max. spacing of 24" OC. Z girt channels attached through the Gypsum Board and the moisture barrier to the wood studs with screws provided by the manufacturer at a max spacing of 24 inches OC. Install mineral wool insulation between the Z girts. Maximum thickness of mineral wool insulation not to exceed 6 in. As per manufacturer's instructions install Acry Metal Channels vertically over the Z girts at a max horizontal spacing of 24 in. OC. Acrytec Panels installed on Acry channel with 1-1/4" long corrosion coated stainless steel screws at a max spacing of 24 in. OC, along with manufacturers approved adhesive (3M 540 or Tremco Vulcum 116). Adhesive to be applied in a zigzag pattern along every channel. Joint treatment in between panels to be Tremco illmod 600 pre compressed polyurethane foam sealant.

C. Non insulated wood strapping system — Install moisture barrier over the Gypsum Board Item 4 and Install 1" x 3" wood strapping vertically at a horizontal spacing not greater than 24 inches OC., over the moisture barrier. 1" x 3" wood strapping attached through the moisture barrier and the Gypsum Board to the Wood studs using fasteners specified by the manufacturer and fasteners spaced max., 24 in. OC. Acrytec Panels to be installed on the 1" x 3" wood strapping using manufacturers approved stainless steel fasteners spaced at maximum 24 inches OC along with Tremco Vulcum 116 adhesive applied in a zigzag pattern along every wood strap. Joint treatment in between panels to be Tremco illmod 600 pre compressed polyurethane foam sealant.

D. Insulated Wood Strapping System — Install moisture barrier over the Gypsum Board Item 4. Install Extruded Polystyrene Insulation over moisture barrier and the Gypsum Board Item 4, max thickness of insulation not to exceed 4 inches. Install 1" x 3" wood strapping vertically at a horizontal spacing not greater than 24 inches OC. Wood strapping attached through the Insulation, the Gypsum Board and moisture barrier to the Wood Studs using fasteners specified by the manufacturer and fasteners spaced max. 24 in. OC. Acrytec Panels to be installed over the wood strapping using manufacturers approved stainless steel fasteners at a max spacing of 24 in. OC and Tremco Vulcum 116 adhesive applied in a zigzag pattern along every wood strap. Joint treatment in between panels to be Tremco illmod 600 pre compressed polyurethane foam sealant.

ACRYTEC PANEL INDUSTRIES — Nominal 5/8 inch thick Acrytec Panel.

*** Indicates such products shall bear the UL or cUL Certification Mark for jurisdictions employing the UL or cUL Certification (such as Canada), respectively.**

Last Updated on 2016-08-31

[Questions?](#)

[Print this page](#)

[Terms of Use](#)

[Page Top](#)

© 2016 UL LLC

The appearance of a company's name or product in this database does not in itself assure that products so identified have been manufactured under UL's Follow-Up Service. Only those products bearing the UL Mark should be considered to be Certified and covered under UL's Follow-Up Service. Always look for the Mark on the product.

UL permits the reproduction of the material contained in the Online Certification Directory subject to the following conditions: 1. The Guide Information, Assemblies, Constructions, Designs, Systems, and/or Certifications (files) must be presented in their entirety and in a non-misleading manner, without any manipulation of the data (or drawings). 2. The statement "Reprinted from the Online Certifications Directory with permission from UL" must appear adjacent to the extracted material. In addition, the reprinted material must include a copyright notice in the following format: "© 2016 UL LLC".